



**19" Standard Rack
Complies to EIA-310-E and IEC-60297-2**

Assembly Guide ARION 800W Series



Patents Pending : 1002000994, 1001000784, 1001000785, 1001000786, 1001000787

Tools and Hardware

Tools Recommended for Assembly



Wireless Screw Driver











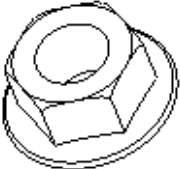

Torque wrench
Hexagon Socket No.10, 24

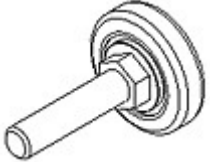

Screw Driver Torx T-30, Phillip No.2
Head Screw Driver

Hardware

			
Screw Torx Head M6x12 33	Flat Washer M16, M6, M4 8, 8, 1	Spring Washer M16, M6, M4 8, 8, 1	Nut Flange M6 4
			
Hex Nut M16, M4 8, 1	Screw Torx Taper M6 2	Hinge Bush 6	Bumper T1.20-4.55 MM 12
			
Closed end cap 6	Leveling Feet M10 4	Nylon Flange Bushing M4 1	Screw Phillip Taper M4 1

Additional parts included in hardware bag.

Note : Extra hardware for optional parts.

- | | |
|---|----|
| 1. Torx head screw M6 x 12 - caster plate | 8 |
| 2. Flange Nut M6 - caster | 16 |
| 3. Flat Washer M6 - caster plate | 8 |
| 4. Spring Washer M6 - caster plate | 8 |

Step 1A: Install vertical frame posts to top and base frames (hand tight only).

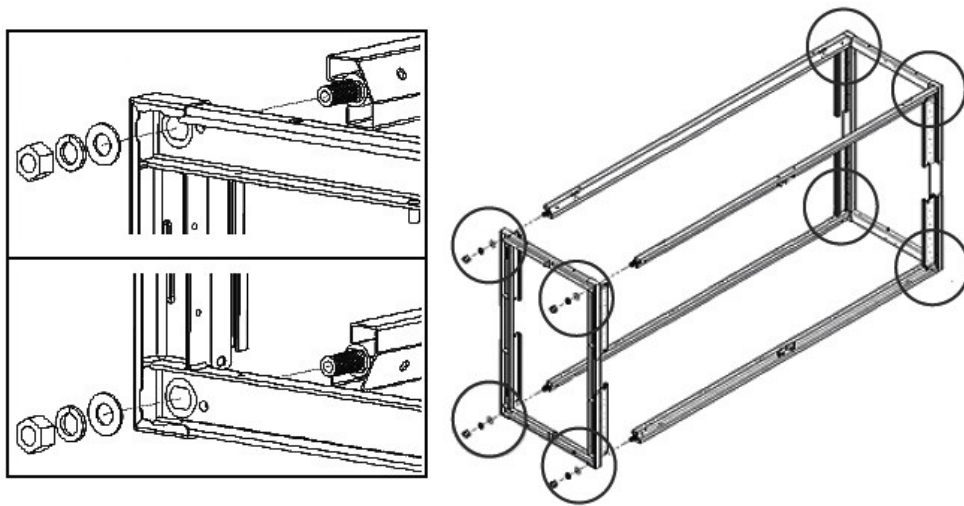

Hardware	Qty.
Flat Washer M16	8
Spring Washer M16	8
Hex Nut M16	8

Step 1B: Tighten vertical frame to top four places (hand tight only).

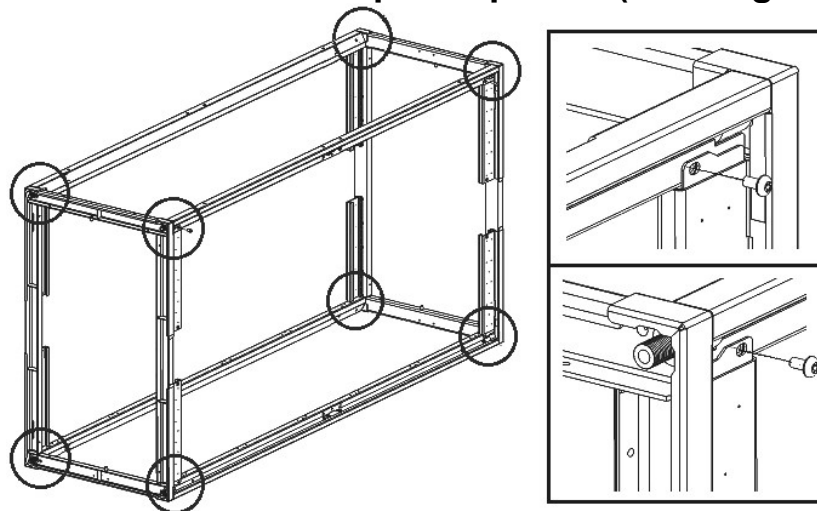

Hardware	Qty.
Torx head screw M6	8

Step 1C: Tighten hex nut M16 and torx head screw M6 x 12.

Use the torque settings below:
65-70 lbs.ft for Hex Nut M16
75-80 lbs.in for Torx head screw M6 x 12



Time Required this step : 8 mins.

Step 2: Install leveling feet to base frame.

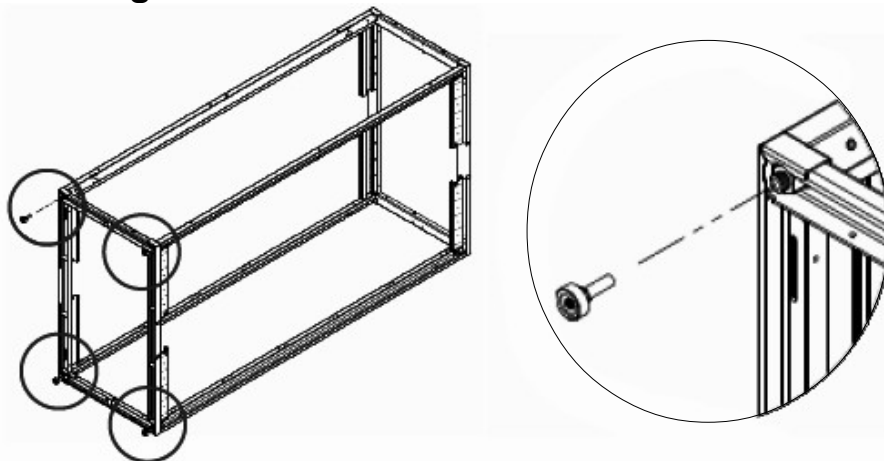

Hardware	Qty.
Leveling Feet	4

Step 2A: Optional Parts : Casters.

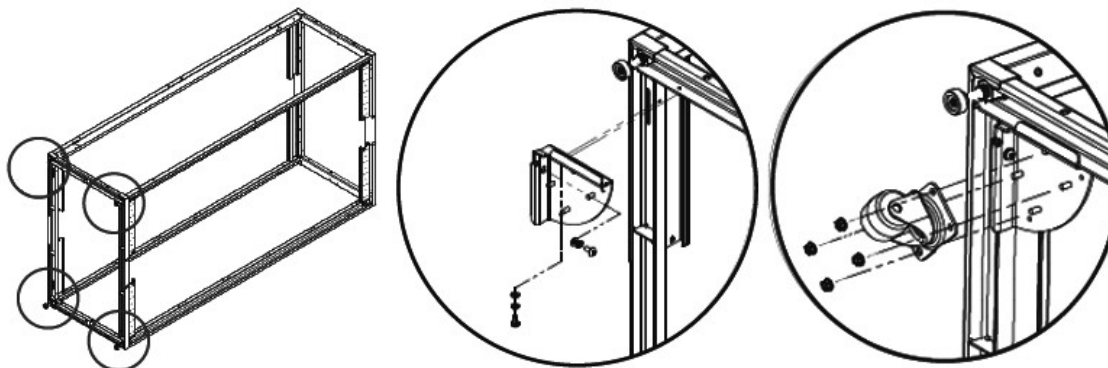

Hardware	Qty.
Flat Washer M6	8
Spring Washer M6	8
Torx head screw M6	8
Caster Plate	4

Set Torque 75-80 lbs.in

Hardware	Qty.
Caster 2.0"	4
Flange nut M6	8

Set Torque 75-80 lbs.in



Time Required this step : 2.3 mins.

Step 3: Install middle side brace, two pieces to frame.

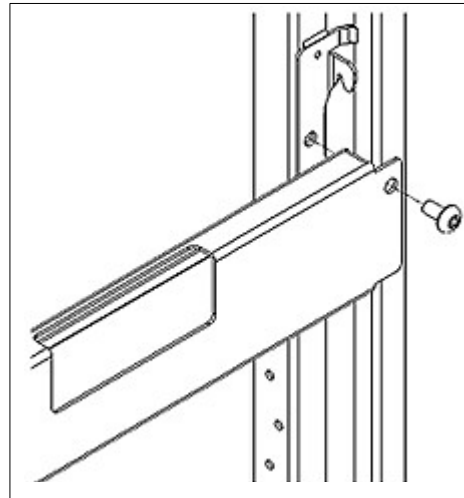
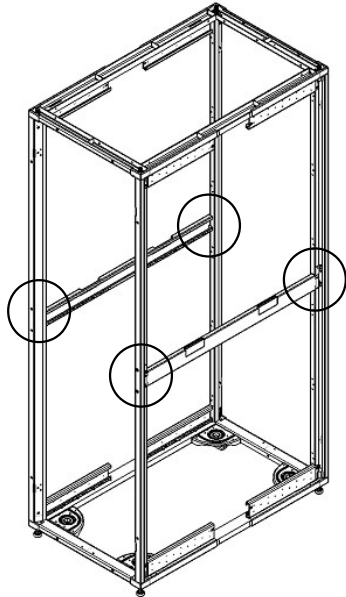

Hardware	Qty.
Torx head screw M6	4



Set Torque 75-80 lbs.in
Time Required this step : 1 mins.

Step 4: Install vertical mounting rails, four pieces, to frame. Select position of rails by using indicator mark 2.

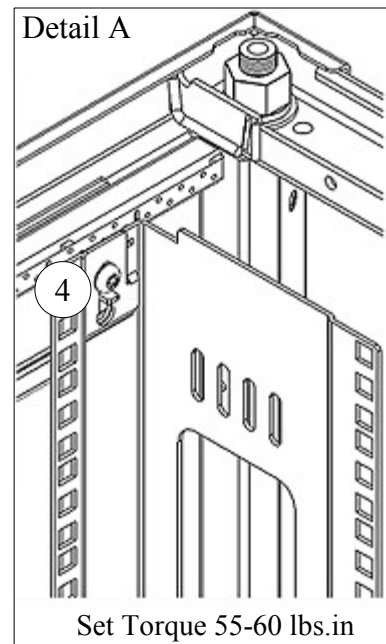
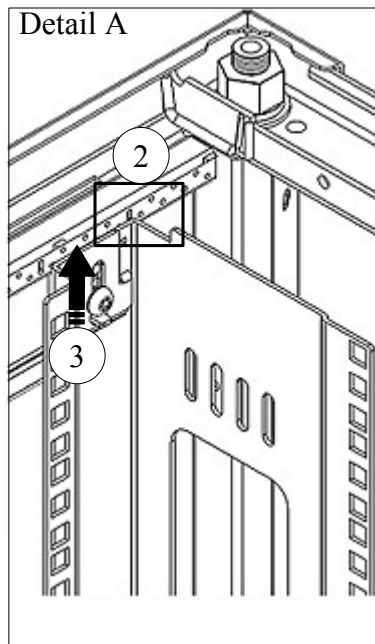
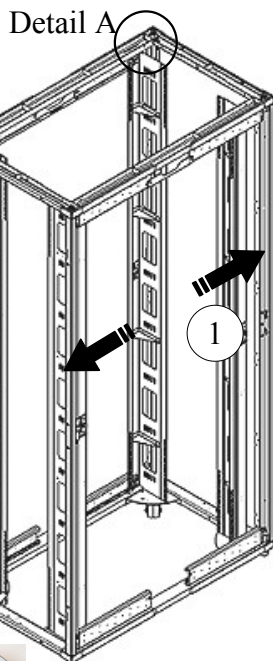

Set Torque 55-60 lbs.in



Time Required this step : 1 mins.

Step 5: Install top panel fixing bracket, 4 pieces to top frame.

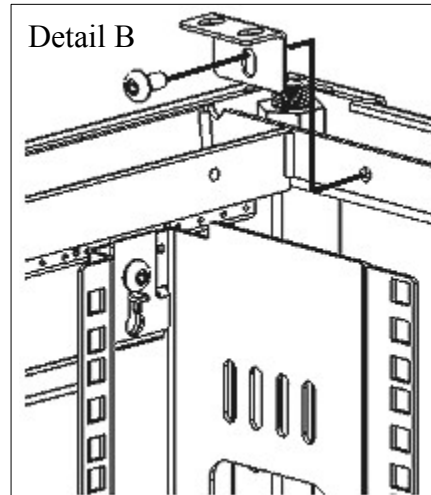
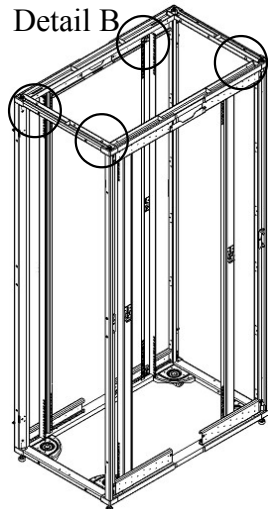

Hardware	Qty.
Torx head screw M6	4

Set Torque 55-60 lbs.in

Step 6: Install top panel to frame top.

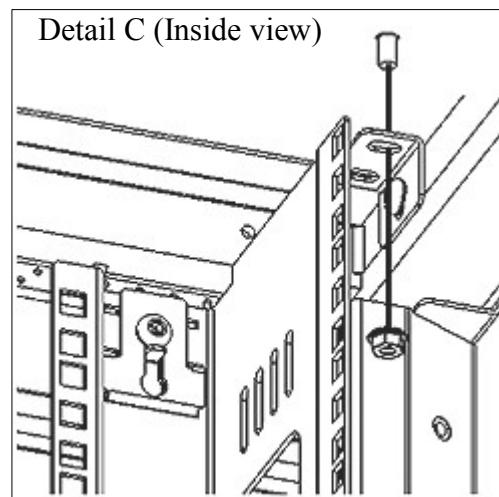
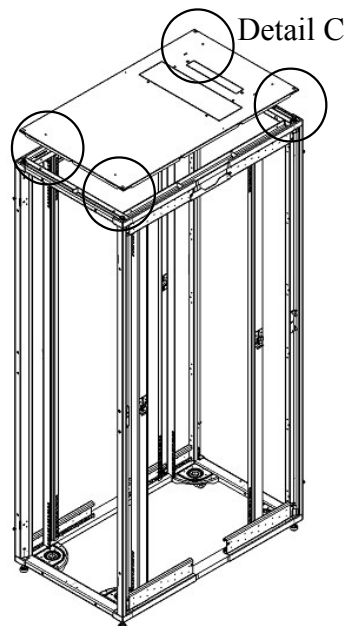

Hardware	Qty.
Nut flange M6	4



Time Required this step : 2 mins.

Step 7: Install the side panel latch bracket frame top.

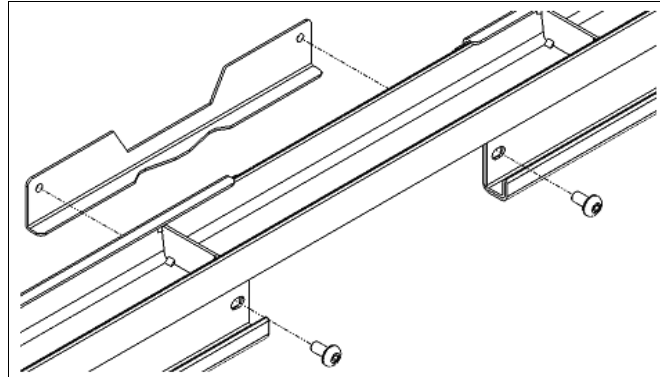
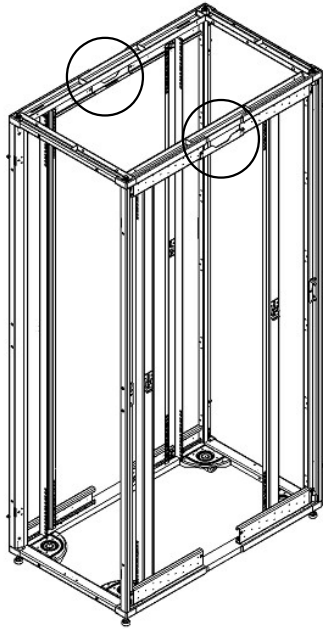

Set Torque 55-60 lbs.in

Hardware	Qty.
Torx head screw M6	4



Time Required this step : 30 secs.

Step 8: Preparation bottom side panel.

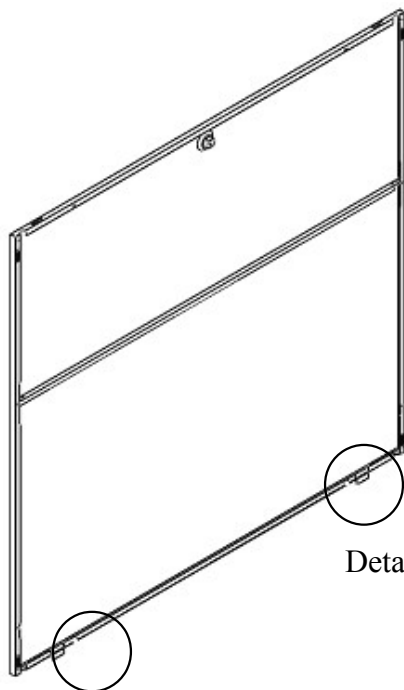

Detail D

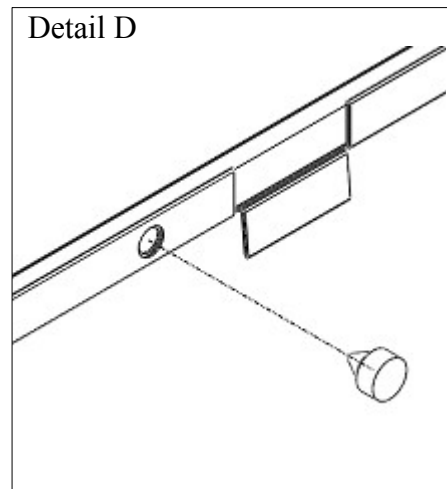

Hardware	Qty.
Bumper T1.2-4.5MM.	4

Step 9: Preparation top side panel.

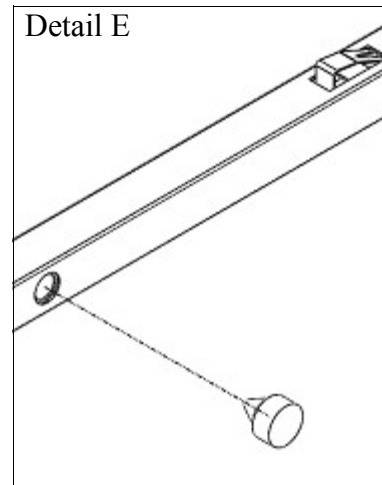
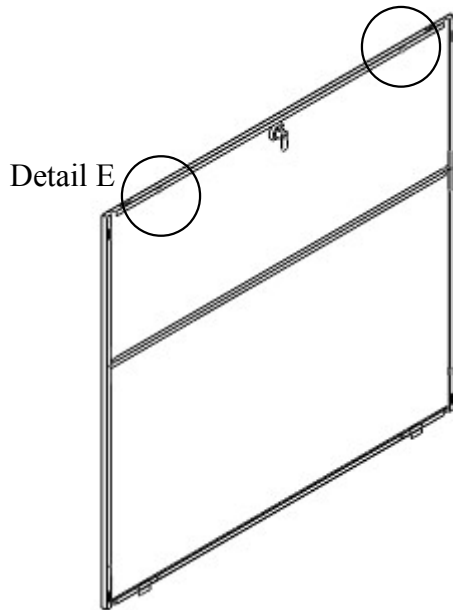

Hardware	Qty.
Bumper T1.2-4.5MM.	4

Step 10: Install bottom side panel and install 4 bumpers onto vertical frames. See detail F.

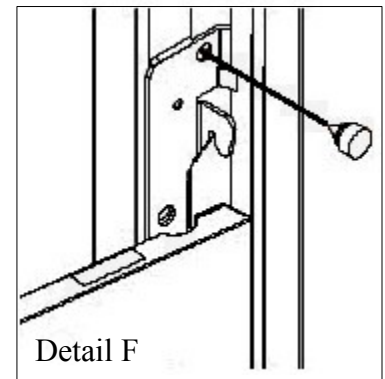
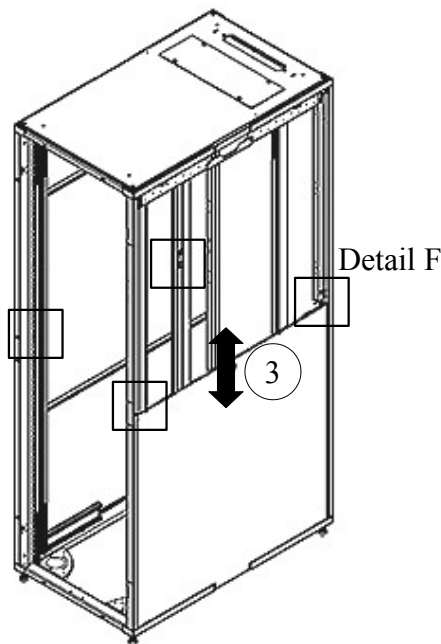
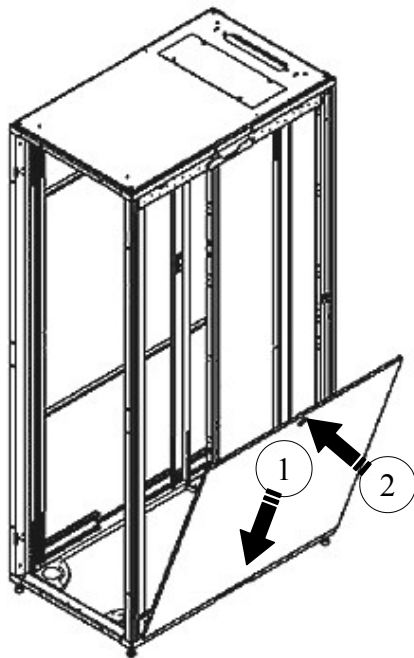

Hardware	Qty.
Bumper T1.2-4.5MM.	4



Time Required this step : 30 Secs.

Step 11: Install top side panel.

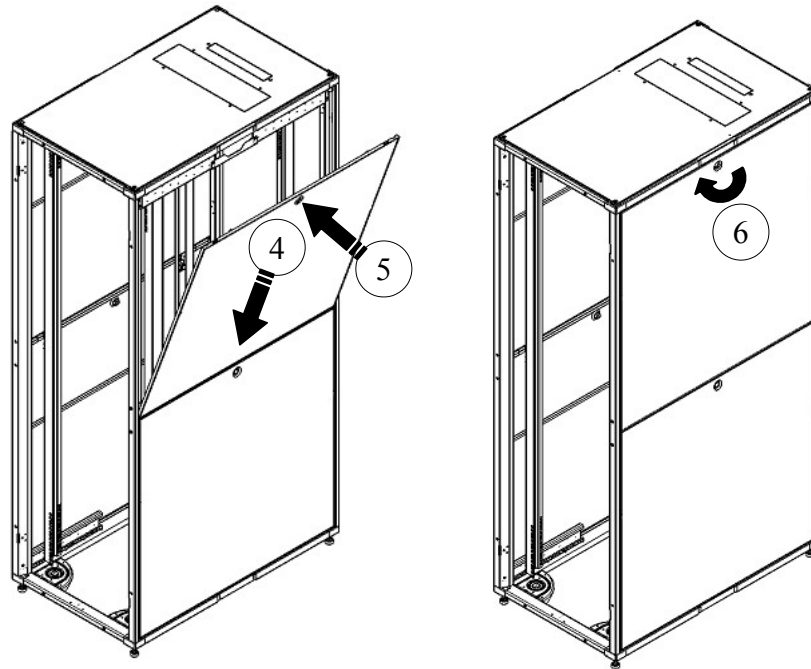

Time Required this step : 30 Secs.

Step 12: Install front door hinges 2 pieces, door latch bracket.

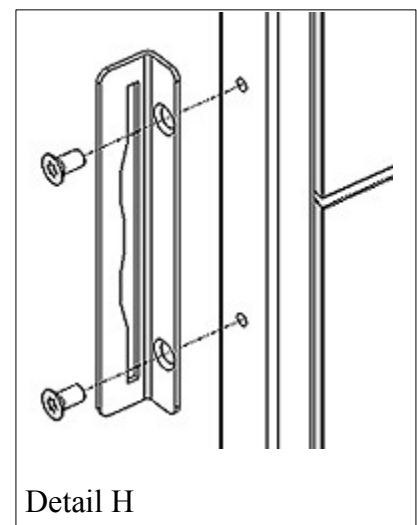
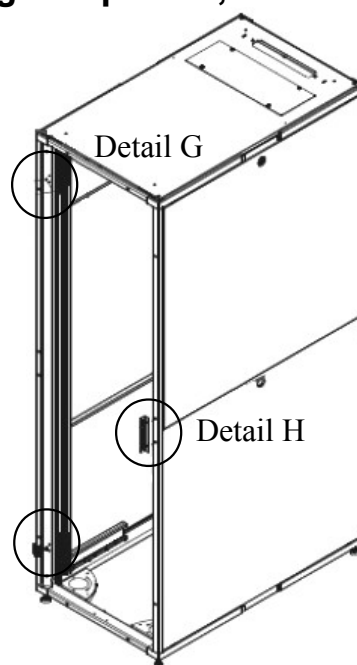
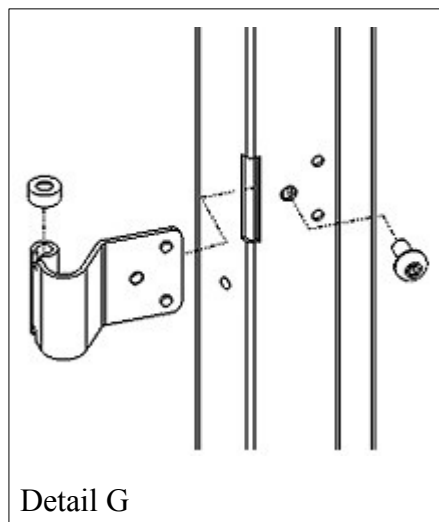

Set Torque 55-60 lbs.in

Step 12A: Install front door and attach ground wire to frame front door.

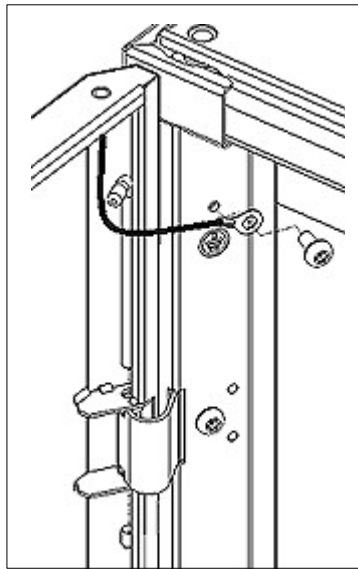

Detail J

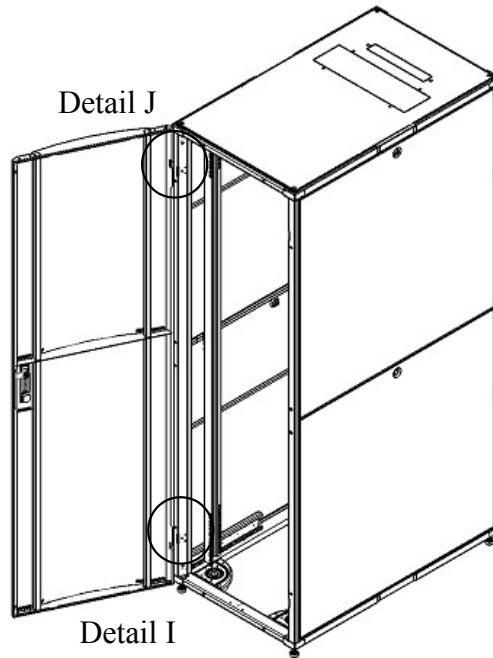

Detail J

Detail I

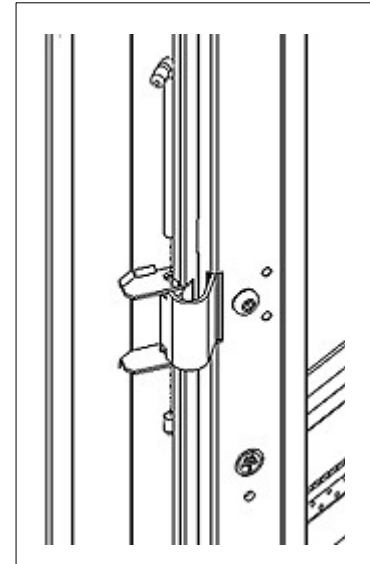

Detail I

Hardware	Qty.
Closed end cap	2
Torx head screw M6	3
Screw torx taper M6	2
Hing bush	2

Set Torque 55-60 lbs.in

Step 13: Install front door stopper.

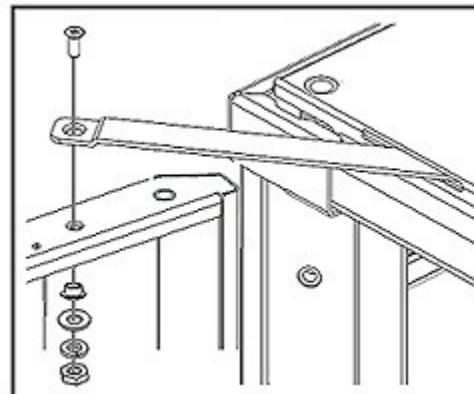
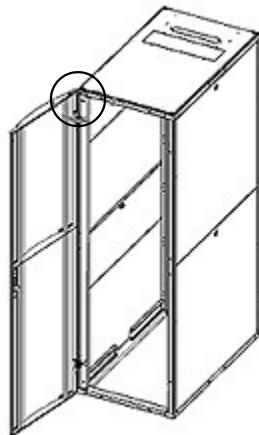

Hardware	Qty.
Flat washer M4	1
Spring washer M4	1
Nylon bush M4	1
Hex nut M4	1
Screw taper M4	1



Time Required this step : 2 mins.

Step 14: Install rear door hinges 4 pieces, split door latch bracket 2 pieces.

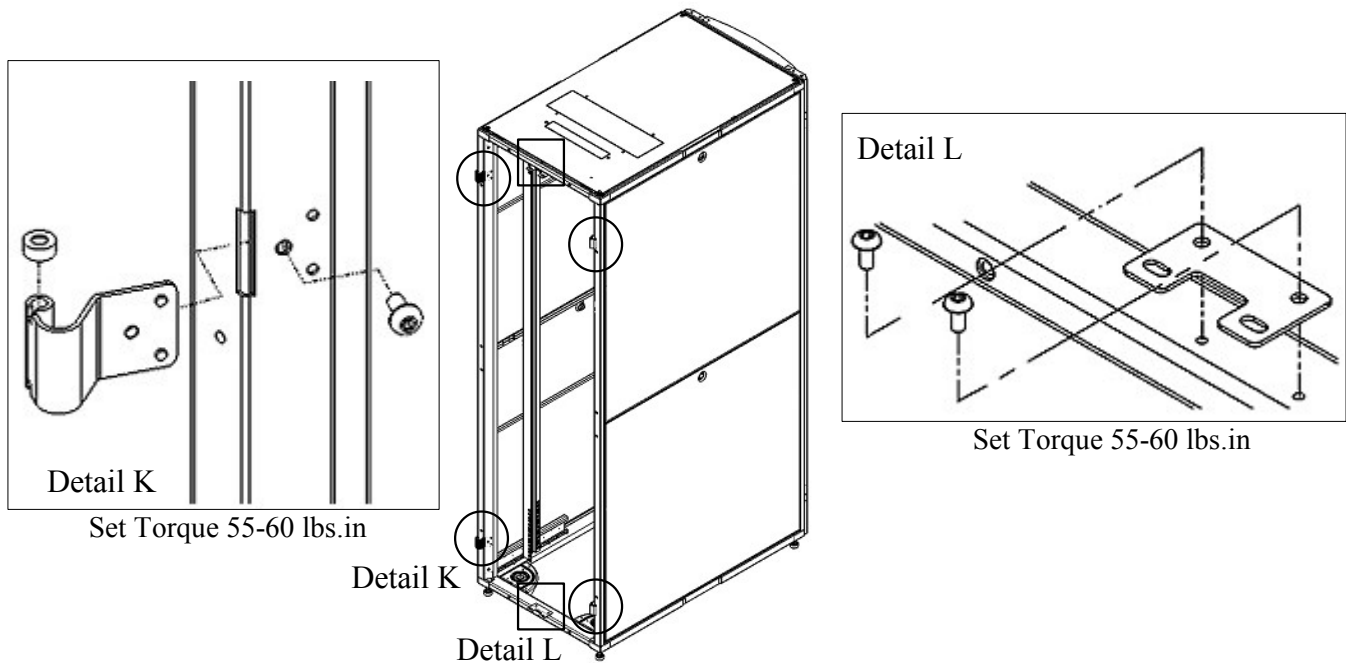

Step 14A: Install rear door and attach ground wire to frame rear door.

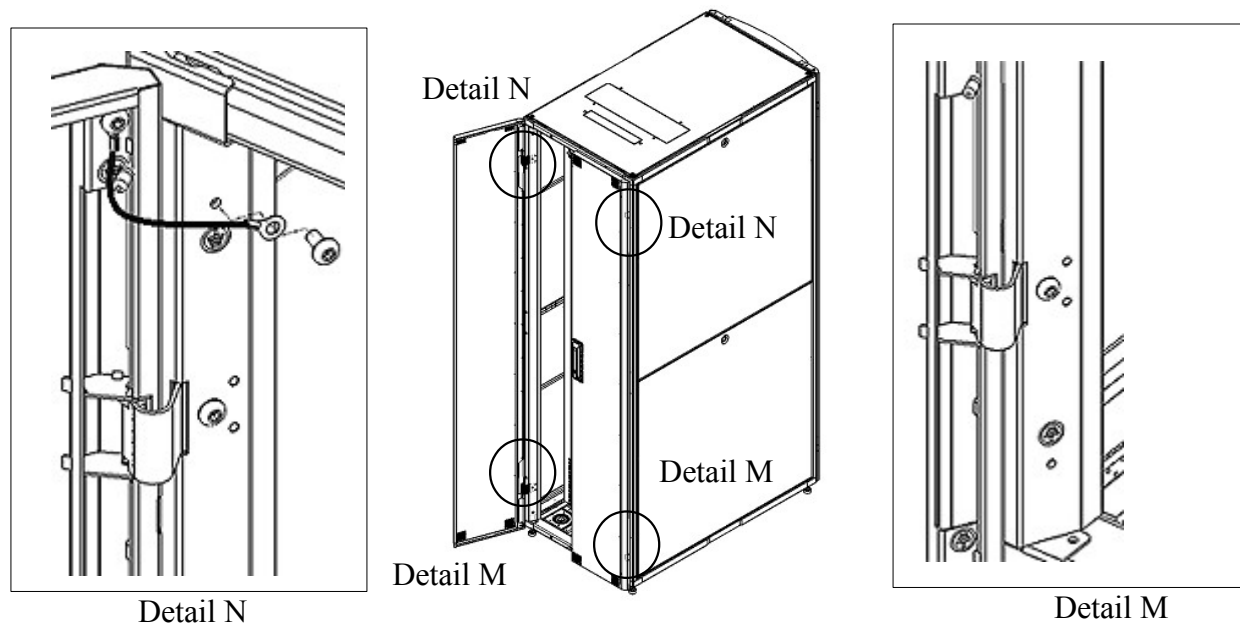

Hardware	Qty.
Closed end cap	4
Torx head screw M6	10
Hinge bush	4

Set Torque 55-60 lbs.in



Time Required this step : 2 mins.

Select Accessories: We have highlighted some popular accessories. Please inquire for additional product availability and information.

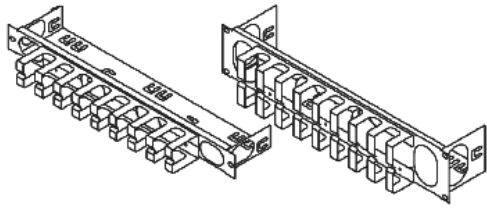

Cable Management Panel Pass Through

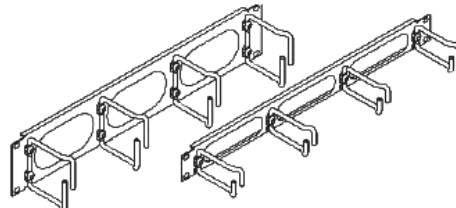

Cable Management Panel Pass Through

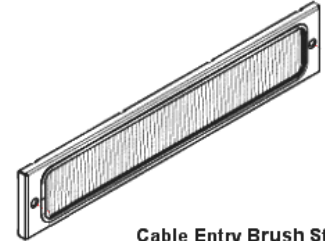

Cable Entry Brush Strip

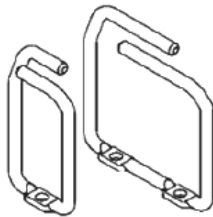

Cable Hoops

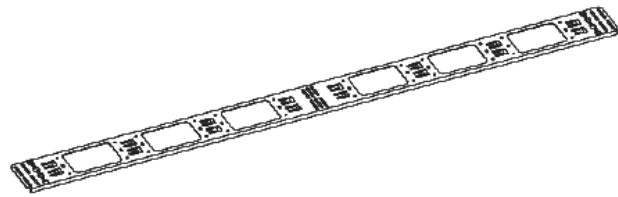

Vertical Cable Rail

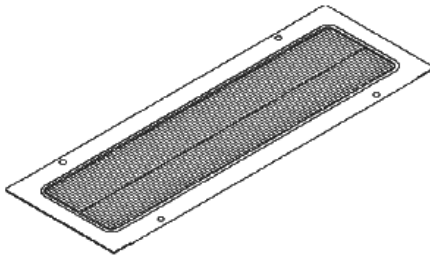

Top Panel Brush Strip

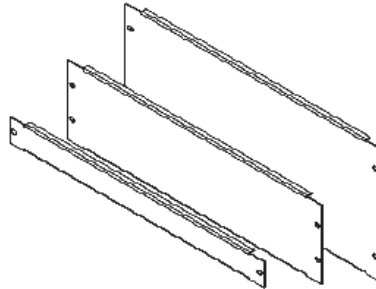

Blank Panel Steel

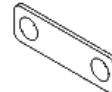

Baying Plate

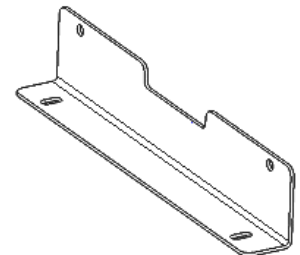

Bracket Bolt Down kit

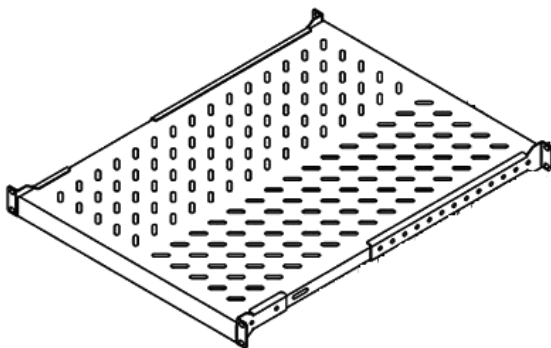

Fixed 19" Shelf

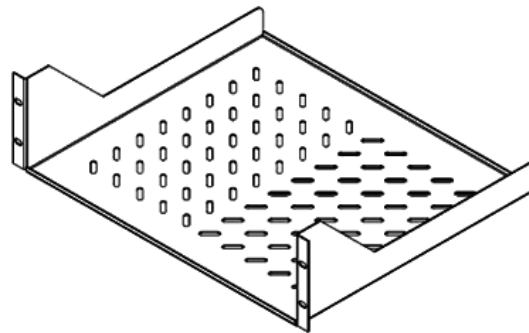

Light Equipment Shelf

**** Install accessories after rack is assembled ****

Thank you for choosing another quality product by

Cheval Group

WWW.CHEVALGRP.COM