



CC Series

General Purpose Electrical Enclosures



The CC Series general purpose electrical enclosure, or control cabinet, is a high quality and versatile line.



The heavy duty steel construction and tough powder-epoxy paint finish make the CC series ideal for industrial applications.

Features :

- Indoor use
- Seven pre-assembled sizes
- Corrosion resistant zinc phosphate dipped steel construction
- Tough exterior of powder-epoxy paint
- Large cable entry area provided
- Cover panel with knock out provided
- Sturdy equipment mounting plate provided
- Easy to open high grade slide latch on cover
- Cabinet standard cream color with orange peel texture
- Mounting panel with smooth texture, color orange
- Custom colors and design modification inquiries welcome

CC-Series Specifications

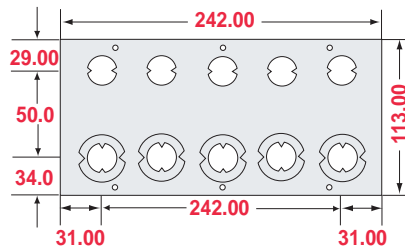
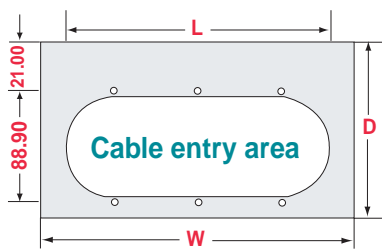
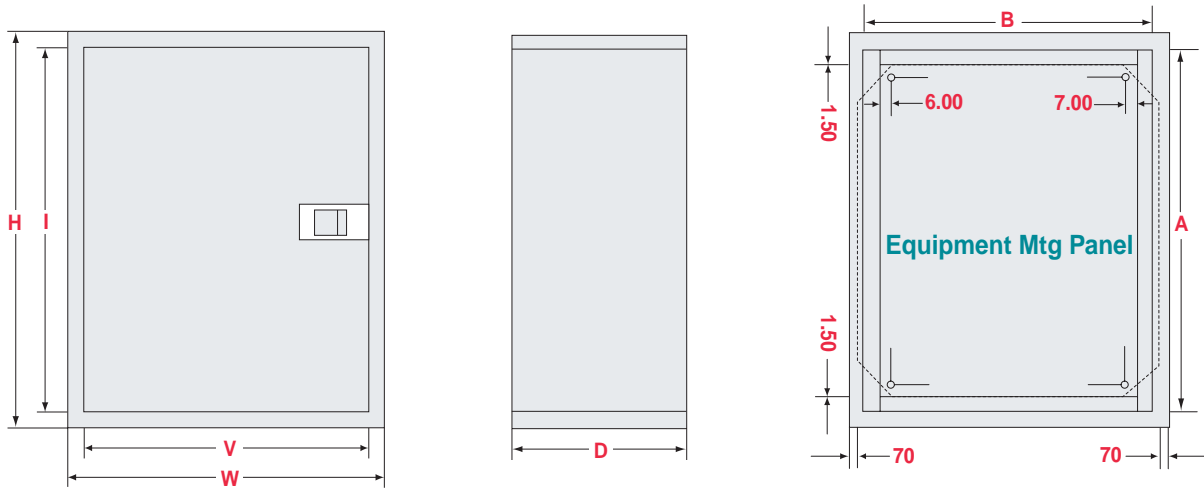

Knock-out Panel
CC-01, 02, 03, 04

Cable entry area

Model	W	D	L
CC-00	280	84	N/A
CC-01	280	160	239.90
CC-02	300	160	239.90
CC-03	350	200	239.90
CC-04	400	200	239.90
CC-05	500	250	419.90
CC-06	650	250	514.90

Knock-out Panel CC-05

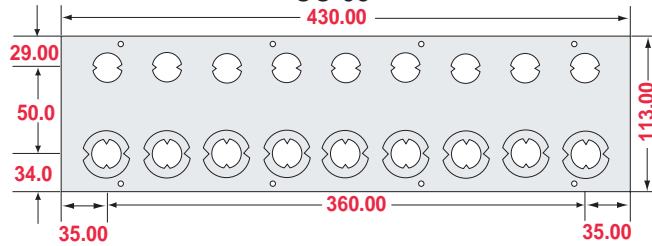

Knock-out Panel CC-06

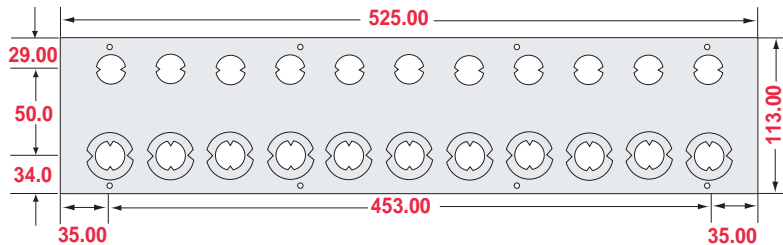

Model	Cabinet Dimensions (mm)						Equipment Mtg. Panel Dimensions			Knock-out
	H	W	D	I	V	Thk.	A	B	Thk.	
CC-00	254	167	84	230	143	0.9	213	126	0.9	25/29 mm.x3
CC-01	350	280	160	318	248	0.9	288	218	0.9	18/32 mm.x 5 22 mm.x 5
CC-02	450	300	160	418	268	0.9	388	238	0.9	18/32 mm.x 5 22 mm.x 5
CC-03	500	350	200	860	310	1.2	430	280	1.2	18/32 mm.x 5 22 mm.x 5
CC-04	550	400	200	510	360	1.2	480	330	1.2	18/32 mm.x 5 22 mm.x 5
CC-05	700	500	250	656	456	1.6	627	427	1.6	18/30 mm.x 9 22 mm.x 9
CC-06	900	650	250	808	606	1.6	827	577	1.6	18/30 mm.x 11 22 mm.x 11