

## Product Information

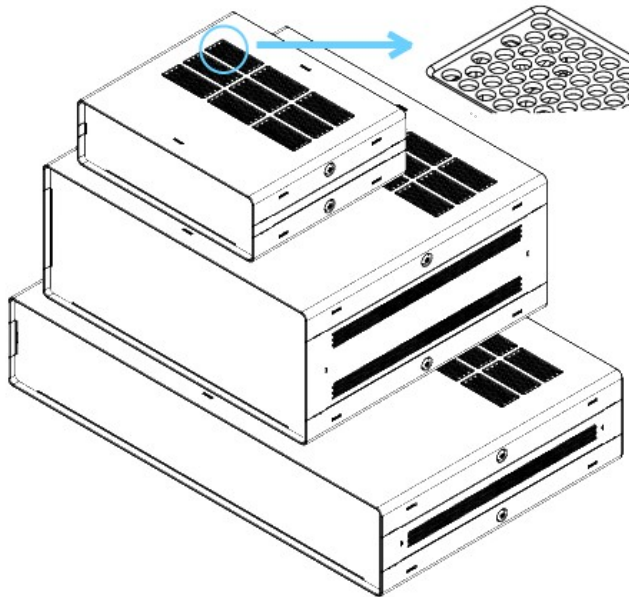

Our SA Series of stand alone general use electronic enclosures is a highly versatile line of quality enclosures for both industrial and hobbyist use. The rugged steel body provides easy access to the components being assembled inside. The Aluminum front and rear panels are ideal for end user customization. Available in 24 different sizes and configurations, the SA Series enclosures come flat packed and its unique "snap together" design requires only 4 screws to complete the assembly.

### Features

- Dimensions to IEC 297
- 24 different sizes and configurations  
Available in :
  - Height : 1.5U to 5U
  - Width : 203, 305 and 432 mm (W1, W2, W3)
  - Depth : 178 and 279 mm (D1, D2)
- Flat packed for convenient shipping and storage
- Quick assembly in approximately 10 minutes, hardware provided
- RoHS compliance
- Conforms to ASTM D610-01 and ASTM B117 (500 hours salt spray test)

### Materials/Finish

- High grade cold rolled steel 0.9 mm thickness.
- Aluminum on Front and Rear panel
- Powder coat finish preceded by 5 stage iron phosphate pretreatment.
- Standard color is low gloss black. Special colors upon request.

### Dimensions

There are 24 different sizes and configurations which are available in :

- Height : 1.5U to 5U
- Width : 203, 305 and 432 mm (W1, W2, W3)
- Depth : 178 and 279 mm (D1, D2)

#### Cheval Electronic Enclosure Co., Ltd.

**International Contact :** Tel : +66 (0) 2315 1504 Fax : +66 (0) 2315 1506  
**Thailand Contact :** Tel : +66 (0) 2744 1632 Fax : +66 (0) 2399 1783

E-mail : commce@chevalgrp.com  
 E-mail : domestic\_sales@chevalgrp.com

Product Information

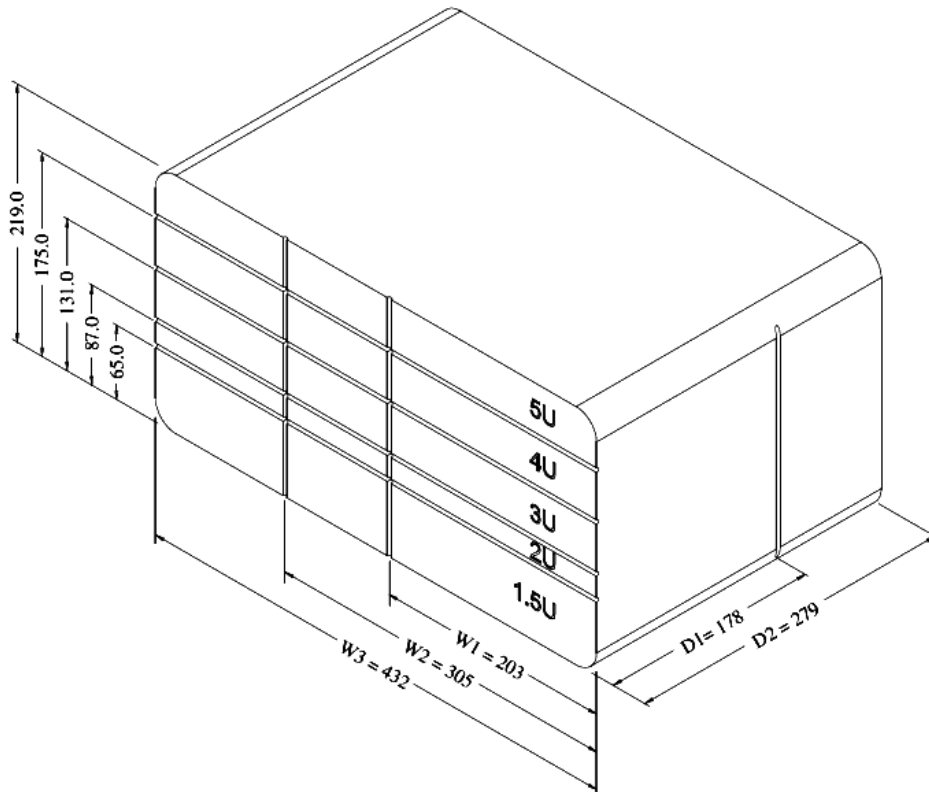

Model Code	Dimension (mm)	Model Code	Dimension (mm)
1.5U-D1-W1	65x178x203	3U-D1-W2	131x178x305
1.5U-D1-W2	65x178x305	3U-D1-W3	131x178x432
1.5U-D1-W3	65x178x432	3U-D2-W1	131x279x203
1.5U-D2-W1	65x279x203	3U-D2-W2	131x279x305
1.5U-D2-W2	65x279x305	3U-D2-W3	131x279x432
1.5U-D2-W3	65x279x432	4U-D1-W2	175x178x305
2U-D1-W1	87x178x203	4U-D1-W3	175x178x432
2U-D1-W2	87x178x305	4U-D2-W1	175x279x203
2U-D1-W3	87x178x432	4U-D2-W2	175x279x305
2U-D2-W2	87x279x305	4U-D2-W3	175x279x432
2U-D2-W3	87x279x432	5U-D2-W1	219x279x203
		5U-D2-W2	219x279x305
		5U-D2-W3	219x279x432

## Product Information

## Part List

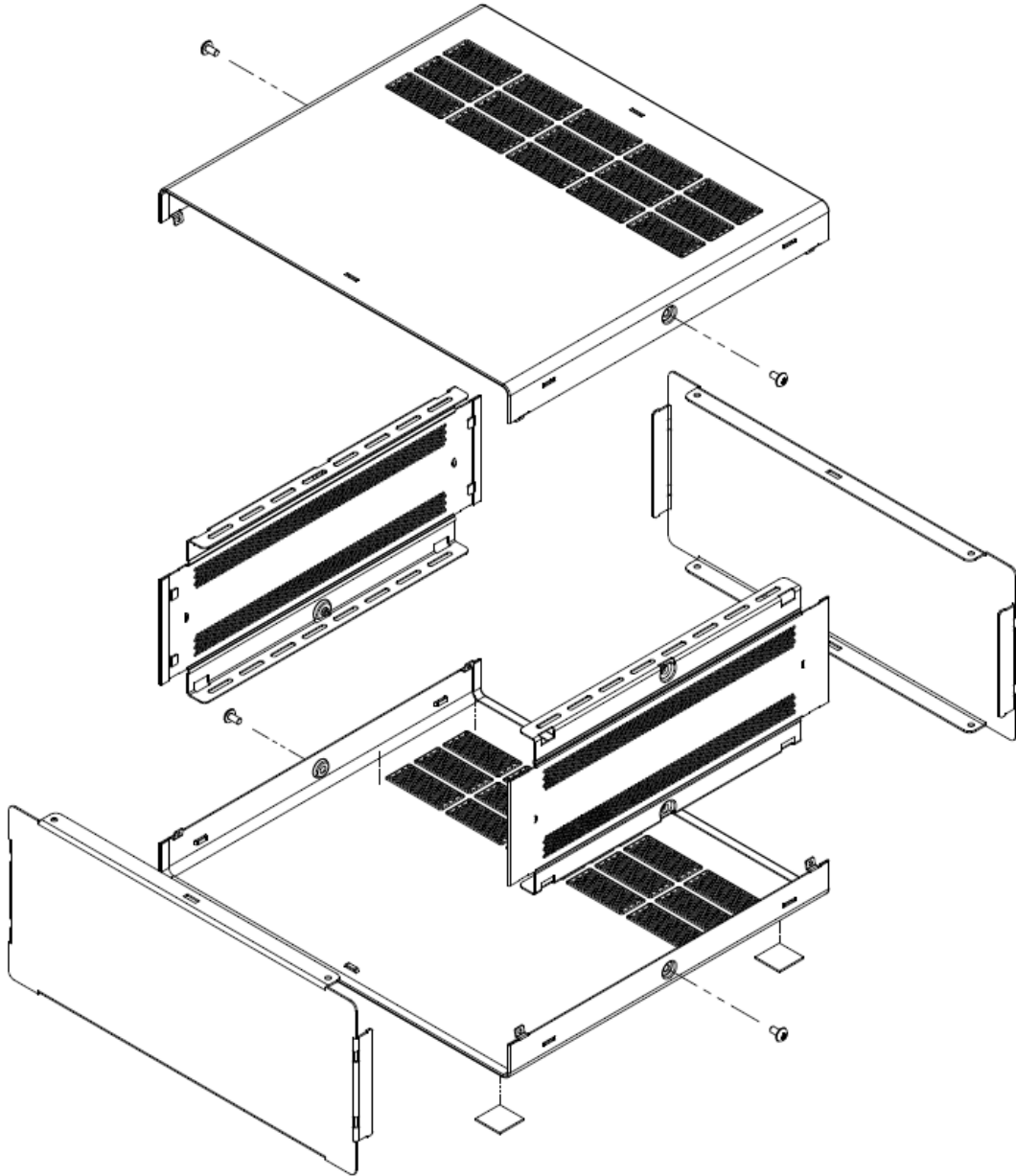

Item	Quantity	Thickness
1. Top Bottom	2 pieces	0.9 mm
2. Side Panel	2 pieces	0.9 mm
3. Front Rear Panel	2 pieces	1.2 mm
4. Umbrella Phillips screw M4x8	8 pieces	
5. Umbrella Phillips screw M3x8	4 pieces	
6. Rubber leg	4 pieces	

## Cheval Electronic Enclosure Co., Ltd.

International Contact : Tel : +66 (0) 2315 1504 Fax : +66 (0) 2315 1506  
 Thailand Contact : Tel : +66 (0) 2744 1632 Fax : +66 (0) 2399 1783

E-mail : commce@chevalgrp.com  
 E-mail : domestic\_sales@chevalgrp.com