

Support Rails (Chassis Runner)

Product Information

When additional support is needed for heavy loads, our support rails provide a suitable option. Available in four depths, the rails mount into the 19" rail side flanges and can support loads up to 50 kg.

Features

- Zero U, easy to install to the inside of the 19" rails
- Support loads up to 50 kg
- Improves rack strength
- ROHS compliant
- Conforms to ASTM D610-01 and ASTM B117 (500 hours salt spray test)

Materials/Finish

- High grade cold rolled steel 1.60 mm thickness.
- Powder coat finish preceded by 5 stage iron phosphate pretreatment.
- Standard color is low gloss black.

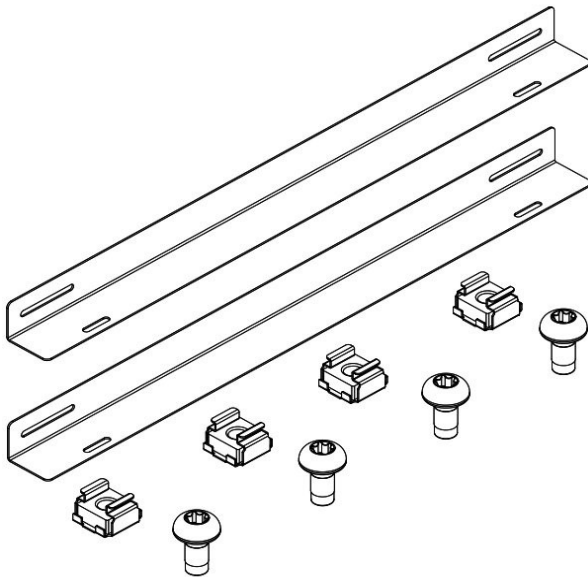

Part Code	Description
SRS650	Support Rails 650 MM
SRS700	Support Rails 700 MM

Dimensions

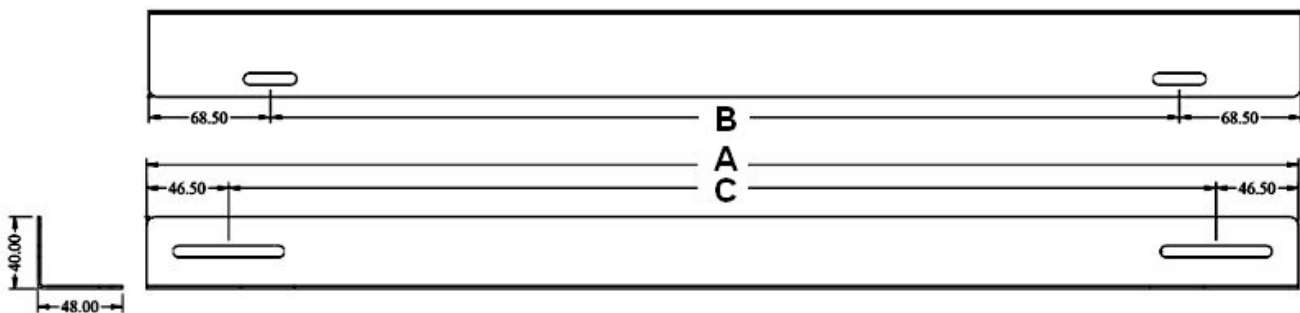

Item	Part Name	A	B	C	Load rated (kg)
1	Support Rails 650 MM	650	513	557	50
2	Support Rails 700 MM	700	563	607	50



Parts List

Item	Part Name	Quantity
1	Support rail	2
2	Cage Nut M6	4
3	Screw pan head M6-12 T-30 (Nyloc)	4

Installation

1. Insert 4 cage nut M6 into square cutout on the rear flange of 4 vertical mounting channel (left/right/front and rear) from outside at the same "U" number
2. Fix support rail to vertical mounting channel with screw pan head M6-12 T-30
3. Tighten 4 screws with T-30 screw driver

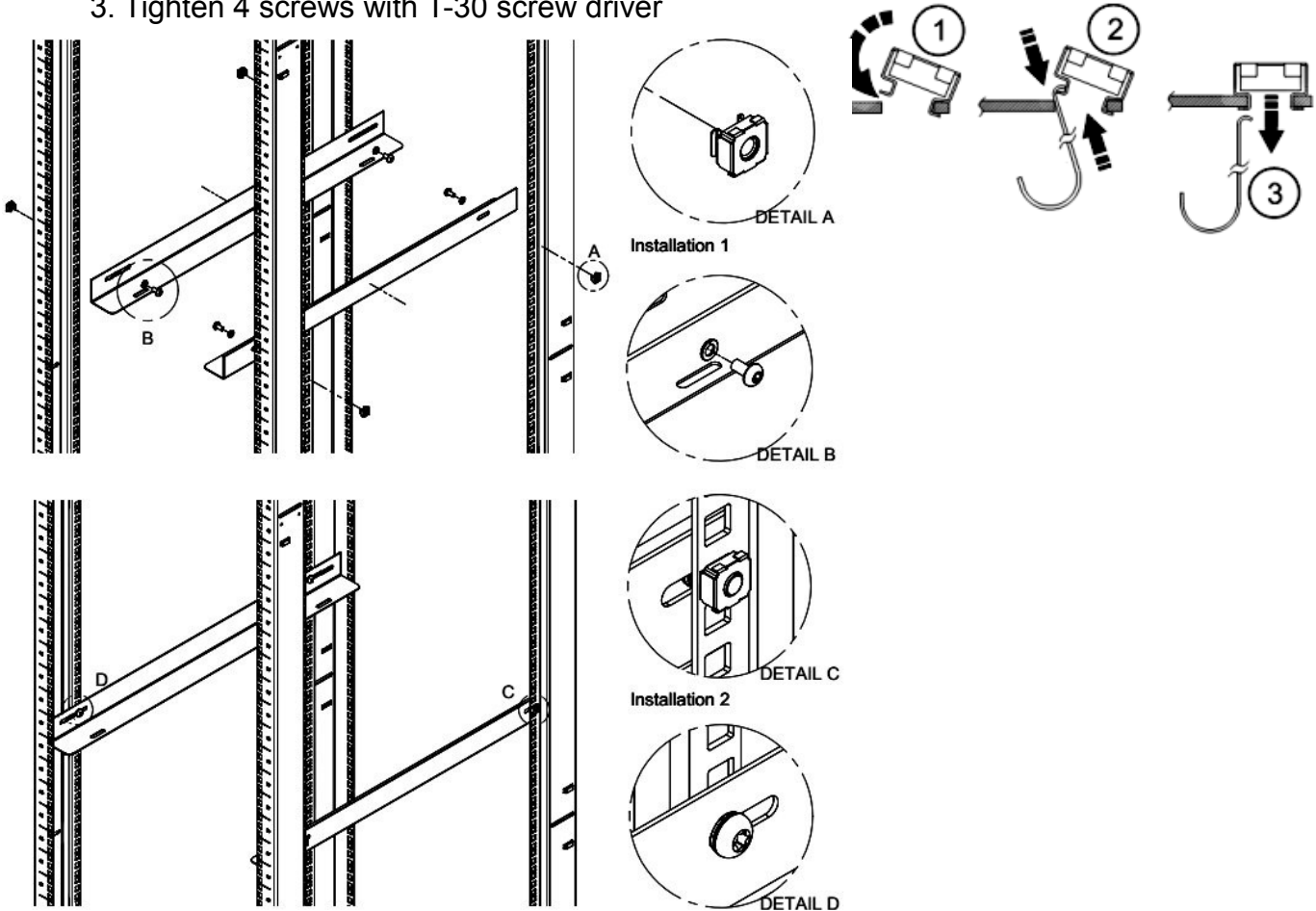

Note : Torque 45-50 in lbs

