

## Light Equipment Shelves 2U/3U Product Information

These shelves mount directly to the front of the 19" vertical rails and can support loads up to 10 kg. Ideal for small non-rack mountable devices. Available in 2U and 3U height.

### Features

- EIA-310E 19" Standard
- Easy to install to the front of the 19" vertical rails.
- 330, 390 and 460 mm depth
- 10 kg load rate
- RoHS compliant
- Conforms to ASTM D610-01 and ASTM B117 (500 hours salt spray test)

### Materials/Finish

- High grade cold rolled steel 1.60 mm thickness.
- Powder coat finish preceded by 5 stage iron phosphate pre treatment.
- Standard color is low gloss black.

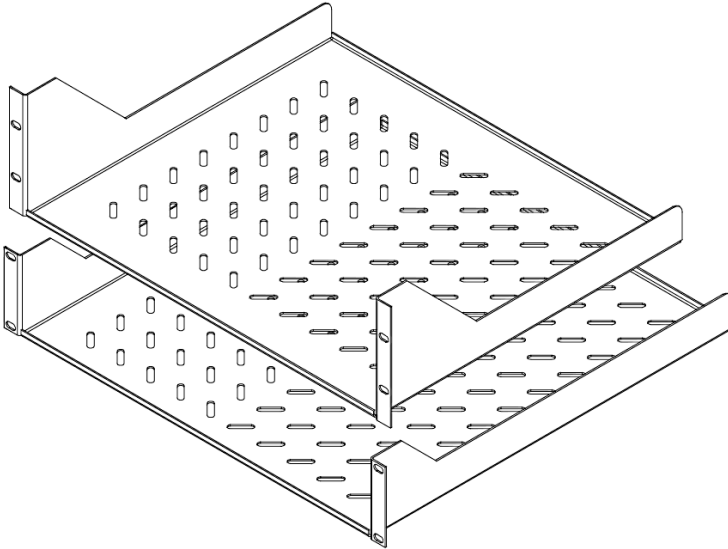

Part Code	Description	"A"	"B"	"C"
SL3302UBLK	Light Equipment Shelves 330 MM 2U Black	330	88	76
SL3902UBLK	Light Equipment Shelves 390 MM 2U Black	390	88	76
SL4602UBLK	Light Equipment Shelves 460 MM 2U Black	460	88	76
SL3903UBLK	Light Equipment Shelves 390 MM 3U Black	390	132	57

### Dimensions

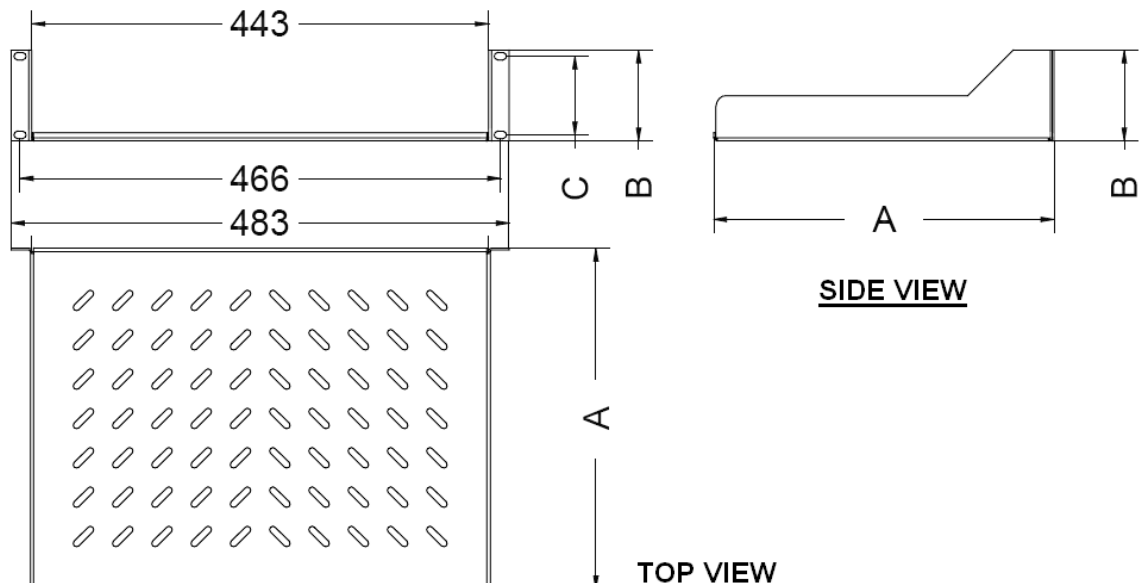

## Parts List

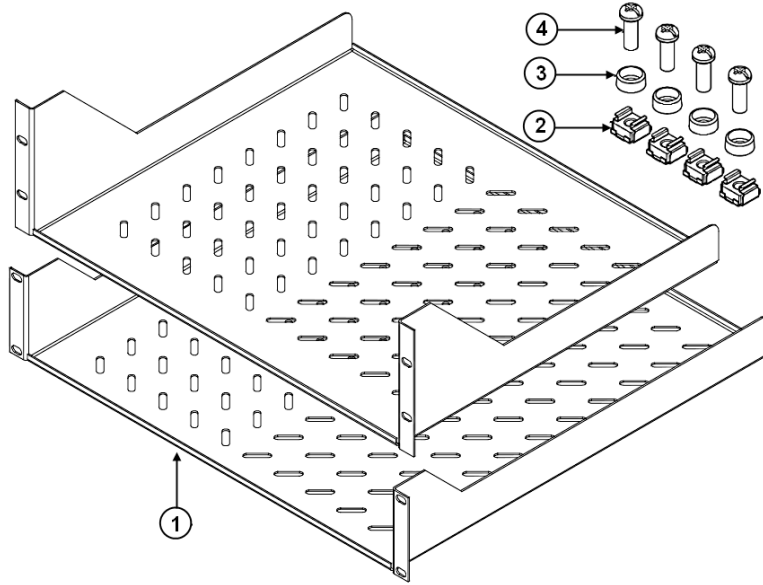

Description	Quantity
1. Light Equipment shelves 2U/3U (330/390/460)	1 piece
2. Cage Nut M6	4 pieces
3. Plastic Cup washer M6	4 pieces
4. Phillips M6x16 pan Screw	4 pieces

## Installation

1. Install 4 Cage nuts into proper hole at desired "U" number on 19" mounting rail.
2. Put Light Equipment Shelf on the front side of mounting rail
3. Insert Phillips screw M6x16 into plastic cup washer then fix these screw and plastic cup washer with Light Equipment Shelf to 19" mounting rail.
4. Align the Light Equipment Shelf in horizontal level then tighten screw with torque 25-30 in lb.

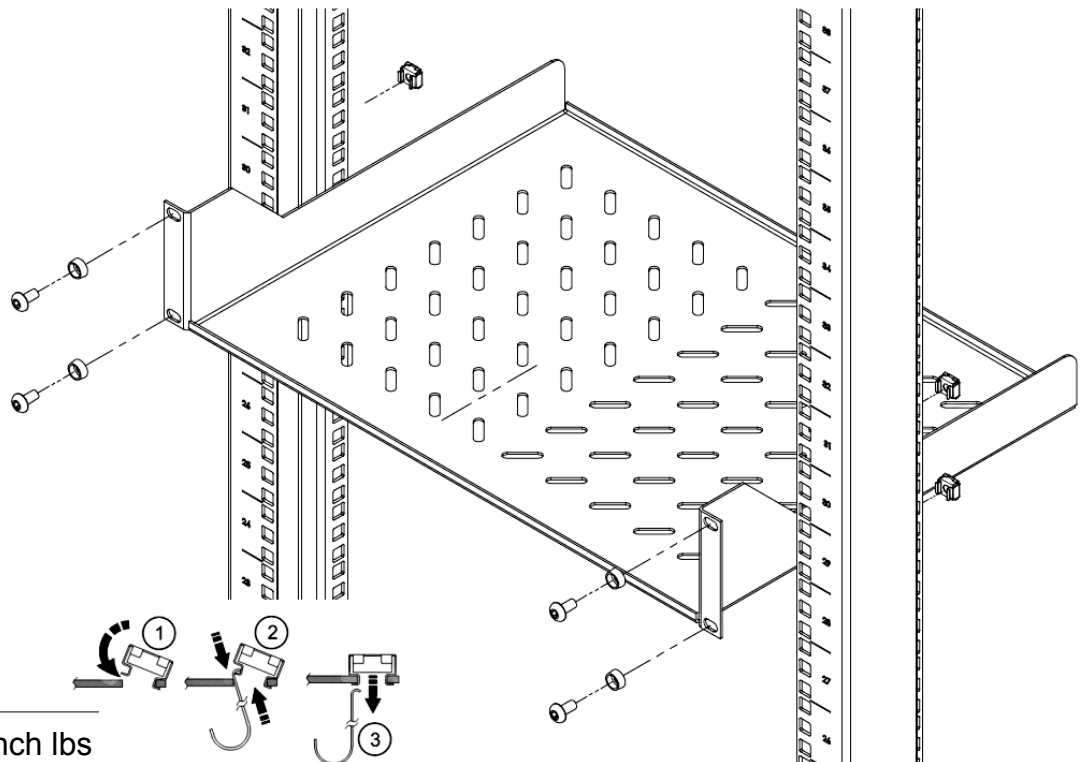

**Note :** Torque 40-50 inch lbs

